

# DDRH240 SERIES

DC/DC Converter input 250-1500VDC 240W



## Features

- 250~ 1500Vdc 6:1 ultra-wide input range
- Withstand 1700Vdc surge input for 10 seconds
- 85.5mm slim width
- 4KVac I/O high isolation(Reinforced isolation)
- Protections: Short circuit / Overload / Over voltage / Over temperature / DC input under voltage / DC input reverse polarity
- Fanless design, cooling by free air convection
- Can be installed on DIN rail TS-35/7.5 or 15
- -40~+80°C ultra-wide operating temperature (> +50°C derating)
- Current sharing up to 960W(3+1)
- Over voltage category II
- Operating altitude up to 5000 meters
- DC OK relay contact
- DC output voltage adjustable(12~15V, 24~29V, 30~36V, 48~58V)

## Applications

- Photovoltaic power generation
- Renewable Energy System
- High voltage frequency conversion
- Industrial control system
- Semiconductor fabrication equipment
- Electro-mechanical apparatus
- DC bus centralized application
- Energy storage system(ESS)
- Charging pile
- Third rail

## Description

DDRH-240 series is a 250 ~ 1500Vdc high reliable ultra-high input DIN rail type DC-DC converter which can supply stable working voltage for the load. It is suitable to be mounted on TS-35/7.5 or 15 rails. Main features are as following: easy to install DIN rail type, narrow width(85.5mm) in slim design, -40~+80°C wide range operating temperature, 4KVac high isolation voltage, current sharing up to 960W(3+1), operation at 5000m altitude, high efficiency, low ripple & noise, complete protections and so on.

DDRH-240 is compliant with BS EN/EN61000-6-2 standard regarding immunity for industrial environments. It is suitable for industrial automation, surveillance, telecommunication and can be widely deployed in the applications of new energy generation such as solar power, and windmill power generation, photovoltaic power systems, high voltage inverting, DC bus centralized application, ESS, charging pile, railway and so forth.

## Model Encoding

DDRH - 240 - 24

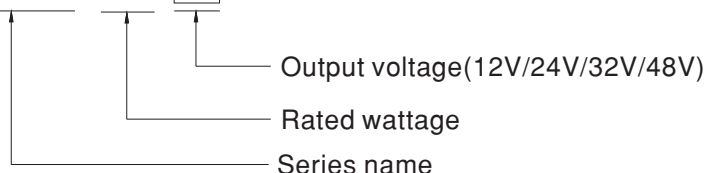

# DDRH240 SERIES

DC/DC Converter input 250-1500VDC 240W



## SPECIFICATION

MODEL		DDRH-240-12	DDRH-240-24	DDRH-240-32	DDRH-240-48	
OUTPUT	DC VOLTAGE	12V	24V	32V	48V	
	RATED CURRENT	16.7A	10A	7.5A	5A	
	CURRENT RANGE	0 ~ 16.7A	0 ~ 10A	0 ~ 7.5A	0 ~ 5A	
	RATED POWER	200.4W	240W	240W	240W	
	RIPPLE & NOISE (max.) Note.2	120mVp-p	240mVp-p	240mVp-p	300mVp-p	
	VOLTAGE ADJ. RANGE	12 ~ 15V	24 ~ 29V	30 ~ 36V	48 ~ 58V	
	VOLTAGE TOLERANCE Note.3	±1.5%	±1.0%	±1.0%	±1.0%	
	LINE REGULATION	±0.5%	±0.5%	±0.5%	±0.5%	
	LOAD REGULATION	±1.0%	±0.5%	±0.5%	±0.5%	
EXTERNAL CAPACITANCE LOAD (Max.)	8000 $\mu$ F	5000 $\mu$ F	4000 $\mu$ F	2000 $\mu$ F		
INPUT	VOLTAGE RANGE Note.4	250 ~ 1500Vdc				
	EFFICIENCY (Typ.)	300Vdc	85%	87%	87%	87%
		800Vdc	88%	90%	90%	90%
		1500Vdc	85%	86%	86%	86%
	INRUSH CURRENT (max.)	COLD START 500A/1500Vdc 300A/800Vdc 120A/300Vdc				
EXTERNAL INPUT FUSE	4A/1500VDC, required(Please refer to page 5 for more details)					
INTERNAL INPUT FUSE	2A/1500VDC (optional)					
PROTECTION	OVERLOAD	105 ~ 135% rated output power Protection type : Hiccup mode when output voltage<35%, recovers automatically after condition is removed; Constant current limiting, recovers automatically after fault condition is removed within 35% ~ 100% rated output voltage				
	OVER VOLTAGE	16.5 ~ 21V	32 ~ 42V	40 ~ 48V	62 ~ 70V	
	OVER TEMPERATURE	Protection type : Hiccup mode, recovers automatically after fault condition is removed				
	DC INPUT	REVERSE POLARITY	By internal Bridge Diode, <b>no damage</b> , recovers automatically after fault condition removed			
	UNDER VOLTAGE LOCKOUT	Under voltage protection range:200 ~ 230Vdc , Under voltage release range:230 ~ 245Vdc				
FUNCTION	DC OK SIGNAL	Relay contact rating(max.) : 30V / 1A resistive				
	CURRENT SHARING	Up to 960W(3+1 units).Please refer to the Function Manual				
ENVIRONMENT	WORKING TEMP.	-40 ~ +80°C (Refer to "Derating Curve")				
	WORKING HUMIDITY	20 ~ 90% RH non-condensing				
	STORAGE TEMP., HUMIDITY	-40 ~ +80°C, 10 ~ 95% RH non-condensing				
	TEMP. COEFFICIENT	±0.03%/°C (0 ~ 50°C )				
	VIBRATION	Component: 10 ~ 500Hz, 2G 10min./1cycle, 60min. each along X, Y, Z axes; Mounting clip: Compliance to IEC60068-2-6				
	OPERATING ALTITUDE Note.5	5000m				
	OVER VOLTAGE CATEGORY	OVC II 2000m, According to EN62109-1				
SAFETY & EMC (Note.7)	SAFETY STANDARDS	IEC62109-1, BS EN/EN62109-1, EAC TP TC 004 approved; Design refer to UL1741(By request)				
	WITHSTAND VOLTAGE	I/P-O/P:4KVAC I/P-FG:2KVAC O/P-FG:2KVAC O/P-DC OK:0.5KVAC				
	ISOLATION RESISTANCE	I/P-O/P, 100M Ohms / 500VDC / 25°C / 70% RH				
	EMC EMISSION	Parameter	Standard		Test Level / Note	
		Conducted	BS EN/EN55032(CISPR32)		Class A	
		Radiated	BS EN/EN55032(CISPR32)		Class A	
	EMC IMMUNITY	BS EN/EN55035, BS EN/EN61000-6-2				
		Parameter	Standard		Test Level / Note	
		ESD	BS EN/EN61000-4-2		Level 3, 8KV air; Level 2, 4KV contact, criteria A	
		Radiated Susceptibility	BS EN/EN61000-4-3		Level 3, 10V, criteria A	
		EFT/Burest	BS EN/EN61000-4-4		Level 3, 2KV, criteria A	
		Surge	BS EN/EN61000-4-5		Level 4, 2KV/Vin+ ~ Vin-, 4KV/Vin~FG , criteria A	
		Conducted	BS EN/EN61000-4-6		Level 3, 10V, criteria A	
Magnetic Field	BS EN/EN61000-4-8		Level 4, 30A, criteria A			
OTHERS	MTBF	214.2Khrs min. MIL-HDBK-217F (25°C); 1391.8Khrs min. Telcordia TR/SR-332 (Bellcore) (25°C)				
	DIMENSION	85.5*125.2*129.2mm (W*H*D)				
	PACKING	0.96Kg; 8pcs/10.3Kg/1.02CUFT				
NOTE	<ol style="list-style-type: none"> <li>All parameters NOT specially mentioned are measured at 800Vdc input, rated load and 25°C of ambient temperature.</li> <li>Ripple &amp; noise are measured at 20MHz of bandwidth by using a 12" twisted pair-wire terminated with a 0.1<math>\mu</math>F &amp; 47<math>\mu</math>F parallel capacitor.</li> <li>Tolerance : includes set up tolerance, line regulation and load regulation.</li> <li>Derating may be needed under low input voltage. Please check the derating curve for more details.</li> <li>The ambient temperature derating of 3.5°C/1000m with fanless models and of 5°C/1000m with fan models for operating altitude higher than 2000m(6500ft).</li> <li>Installation clearances : 40mm on top, 20mm on the bottom, 5mm on the left and right side are recommended when loaded permanently with full power. In case the adjacent device is a heat source, 15mm clearance is recommended.</li> <li>The power supply is considered a component which will be installed into a final equipment. The final equipment must be re-confirmed that it still meets EMC directives.</li> </ol>					

# DDRH240 SERIES

DC/DC Converter input 250-1500VDC 240W



## Block Diagram

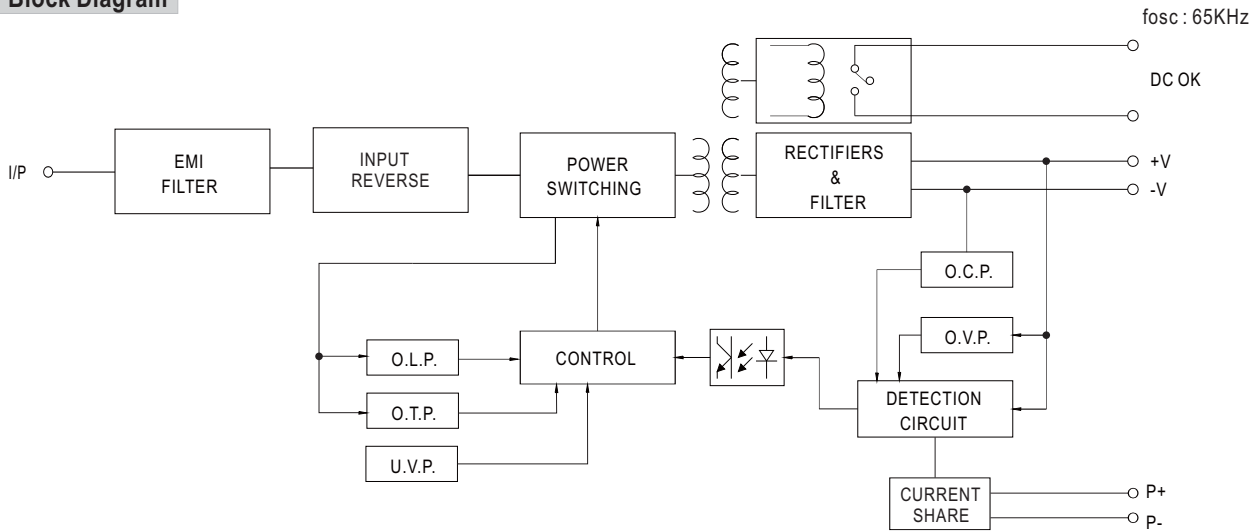

## Derating Curve

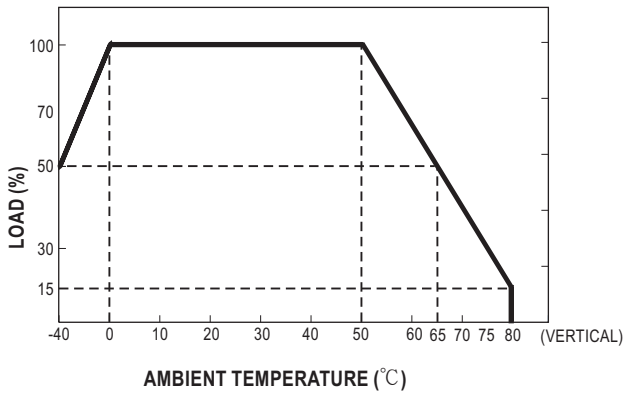

## Static Characteristics

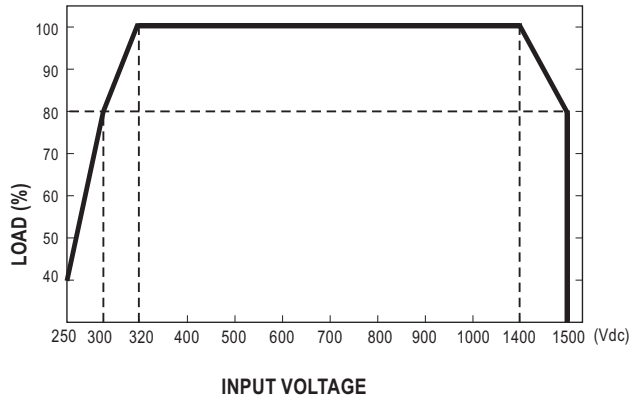

## Altitude Curve

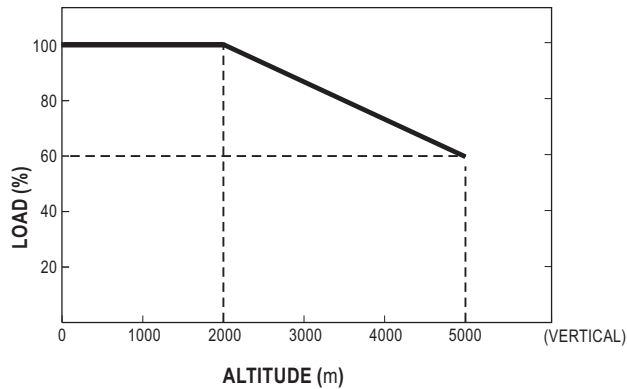

Note: Multiply by the regular power limit factor

# DDRH240 SERIES

DC/DC Converter input 250-1500VDC 240W



## ■ DC OK Relay Contact

Contact Close	PSU turns ON / DC OK.
Contact Open	PSU turns OFF / DC Fail.
Contact Ratings (max.)	30V/1A resistive load.

## ■ Function Manual

### 1. Current sharing

- (1) Parallel operation is available by connecting the units shown as below (P+,P- are connected mutually in parallel) .
- (2) The voltage difference among each output should be minimized that less than 0.2V is required.
- (3) The total output current must not exceed the value determined by the following equation (Output current at parallel operation)  
$$=(\text{The rated current per unit}) \times (\text{Number of unit}) \times 0.9.$$
- (4) In parallel operation 4 units is the maximum, please consult the manufacture for other applications.
- (5) When in parallel operation, the minimum output load should be greater than 3% of total output load.  
(Min. load > 3% rated current per unit x number of unit)
- (6) In parallel operation,after overload or short circuit fault occurs, re-power on to recover.

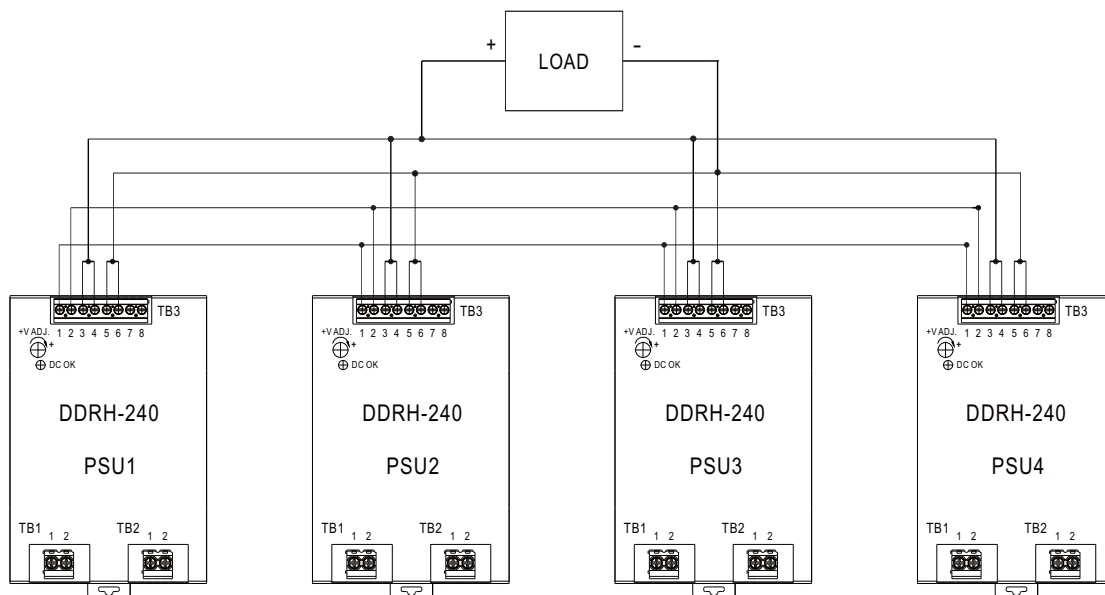

# DDRH240 SERIES

DC/DC Converter input 250-1500VDC 240W



## Mechanical Specification

Terminal Pin No. Assignment (TB3)

Pin No.	Assignment
1	P+(Current sharing)
2	P-(Current sharing)
3,4	+Vo
5,6	-Vo
7,8	DC OK Relay Contact

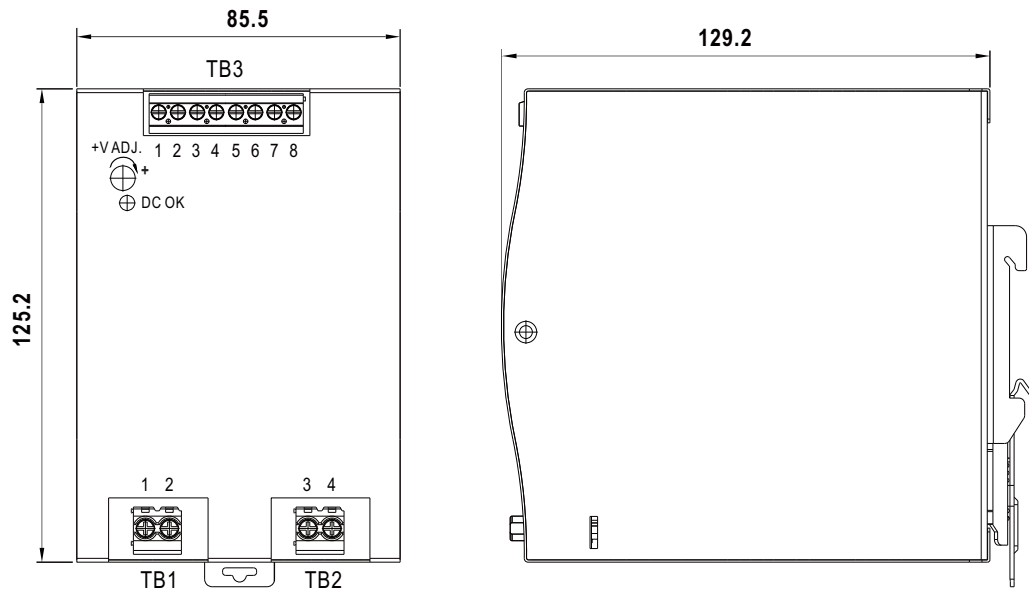

Terminal Pin No. Assignment (TB1, TB2)

Pin No.	Assignment
1,2	-Vin
3,4	+Vin

## External FUSE wiring instruction

External FUSE is required. FUSE specification : 4A/1500Vdc.

Suggested model:

Fuse Brand	Manufacturer Part NO.		MW's Order NO.
	Fuse	Fuse Holder	Fuse + Fuse Holder
WalterFuse	WJ30-4	WJ30-H	<a href="#">WJ30-4_WJ30-H</a>

